



INSTALLATION INSTRUCTIONS

SENSING EDGE

US Patent 6,571,512 Other patents apply. 

MODEL: MG110

WARNING

Read and understand all instructions before beginning installation. Disconnect power to motor and test upon completion. Sensing edges should be installed by qualified personnel to ensure the requirements herein have been met. Keep these instructions with the installation. Always abide by local and national electrical code specifications when wiring accessories to motor controls.

The MG110 sensing edge is a UL Recognized Component that meets the UL 325 requirement and is compatible with most operator brands. Consult your operator manual for detailed instructions about connecting to the motor.

CONTENTS

- MG110 sensing edge
- MG110-C mounting channel
- (2) End caps
- (2) Self-drilling mounting screws

REQUIRED

- 5/16" socket
- Junction box
- 22 gauge wire

SUGGESTED

- Operator installation manual
- Edge Tester (MET-101)
- Ohm meter (capable of measuring 10K)

I. INSTALLATION SETUP

1. All Miller Edge sensing edges are inspected and tested prior to shipment to ensure quality. Upon opening the shipping box, inspect your sensing edge and wiring for shipping damage. If the shipping container appears to be damaged, please notify carrier immediately.
2. Un-box and lay the sensing edge out straight. This will allow the edge to relax and return to its original shape.

II. INSTALLATION

1. Pre-drill a 1/4" hole 1/4" from each end of the mounting channel.
2. Use provided self-drilling screws to secure cap through the channel to mounting surface. Wire to controls.

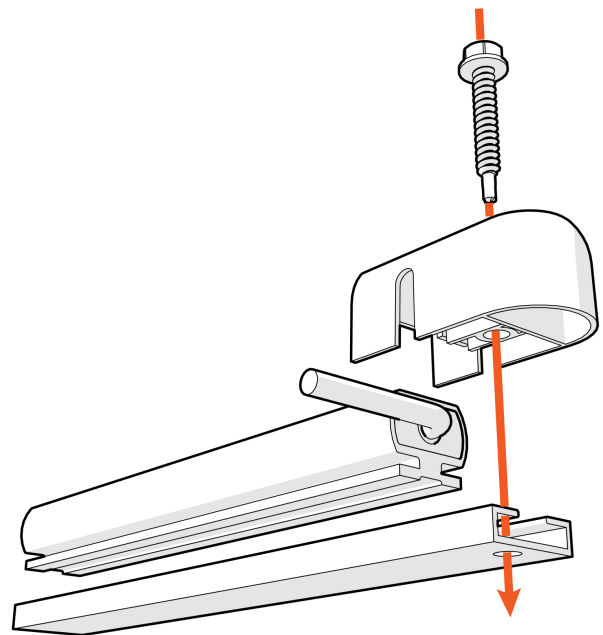

MG110_INST_20190304

III. TECH SUPPORT

For additional assistance, contact Miller Edge Tech Support: 800-220-3343

IV. GENERAL SPECIFICATIONS

Length	Stock lengths: 4 ft., 5 ft., or per specification +/- .25"
Lead Wire	SJTO, 22 gauge, 2' length
Sensitivity	Nominal 4-7 lbf
Electrical Maximum	24 volts AC/DC, 1/2 amp
Contact Element	Alumaglas®
Materials	Flexible PVC
Temperature Rating	-30°F to +155°F (-34°C to +68°C)
Wire Outlet Location	Field selectable left or right
Ratings	UL 325 Recognized Component

V. CONFIGURATOIN OPTIONS

- 2-Wire 8.2K monitored (T1/green band)
- 2-Wire 10K monitored (T2/blue band)
- 2-Wire capacitor (T4/white band)
- 2-Wire non-monitored

VI. MAINTENANCE

It is strongly recommended that users test sensing edges at least once per month. Check the sensing edge for cuts, loss of sensitivity, or water damage. Also check for signs of damage to cables or connection points. Compress the sensing edge 2" from both ends and in the center and observe that it sends an electric signal to the controls. Refer to your operator manual for detailed instructions about motor connections.

VII. REPLACEMENT

To replace your Miller Edge Sensing Edge, contact your sales representative. Attempting to repair your Miller Edge Sensing Edge is not recommended and will void the manufacturer warranty.

VIII. WARRANTY

MG110 carries a **1-year warranty** from date of shipment from Miller Edge for credit or replacement. This warranty applies to normal use, which is found to have defective materials or workmanship, as determined solely by an authorized factory representative. This warranty is void where evidence of misuse or abuse is present. This warranty covers repair or replacement of the purchased product only; product installation/labor charges are not covered. Miller Edge manufactures its products to meet stringent specifications and cannot assume responsibility for those consequences arising from improper installation or misuse. Installation instructions and testing procedures provided by Miller Edge must be followed for proper operation and maintenance.