



PRODUCT DESCRIPTION

Intrinsically safe controller for use with mats and sensing edges in hazardous locations

FSIS-25-4	Controller in Enclosure 10" x 7 1/2" x 7" (254mm x 190mm x 178mm)
FSIS-25-4P	Controller Only - 4 3/4" x 4 1/2" x 3 1/2" (no enclosure) (120mm x 115mm x 89mm)

SPECIFICATIONS

Input: 4-Wire GuardianMat® (up to 4 mats)

Output: 1 SPDT output

Output Relay: Switching Amplifier

Output Relay Approvals: FM, UL, CSA, PTB, SEV

Output Contacts: 4A @ 250VAC, 4A @ 24VDC

Response time: <0.020 sec. calc.

Power input: 120VAC +10% - 15%

Enclosure: Explosion Proof, NEMA 3,4,7&9

10" x 7.5" x 7"

(254mm x 190mm x 179mm)

DESIGN FEATURES

- Intrinsically Safe
- Approved for hazardous locations
NEMA Class I, II, III,
Div. 1 ,2 Groups A-G
- Limits voltage and current to the sensor to a degree that any shortage or breakage will not cause a spark.
- One LED status indicator
- Available with or without enclosure

FSIS-25-4 Wiring Diagram

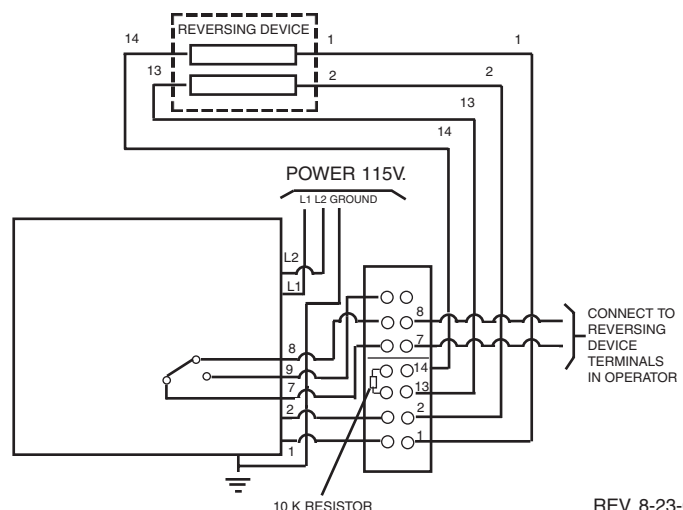

REV. 8-23-04