

PRODUCT DESCRIPTION

The Microcell One Infrared Beams (10MICROCELL1S/ D/ L) respond to the evolution of requirements in the area of safety for automatic pedestrian doors. Because of their reduced size, they can be discretely integrated into any door-frame. The increase in micro-processed door operators, the setting of new safety standards, and the concern for better protection of pedestrians have driven the development of a more flexible, more effective new line of safety beams.

COMPONENT ID

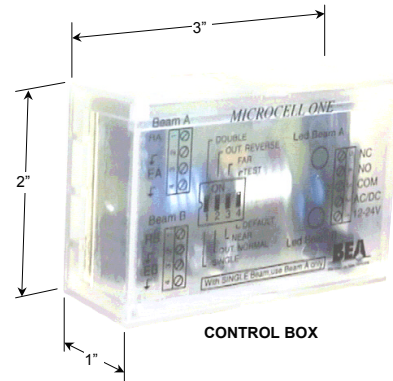
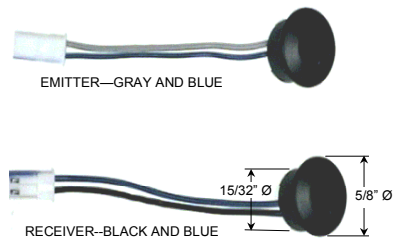

TECHNICAL SPECIFICATION

DESCRIPTION	SPECIFICATION
Technology	Microprocessed active infrared
Mounting Height	Minimum 1' above floor
Distance between pairs of beams	Minimum 1' (note: beams must be crossed)
Distance between heads and the plane of the doors	1"
Range of detection	Minimum 3' - Maximum 15'
Alignment tolerance	8°
Detection method	Presence (by beam interruption)
Response time	≤ 40 ms
Hold time	300 ms
Power supply	12 - 24 V AC ± 10% 12 - 24 V DC -5% / +30%
Consumption	< 100 mA
Output contact rating	1 Relay (NC/NO contacts) 50 V DC / 50 V AC 1 A (resistive) 30 W (DC) / 60 VA (AC)
Displays	2 Red LEDs, lights when barrier is interrupted
Adjustments	Dip switches
Operating temperature	-30° to +131° F
Immunity	<ul style="list-style-type: none"> Ambient light Incandescent light Electromagnetic compatibility
Protection	Nema 4 Enclosure (IP 65)
Dimensions	<ul style="list-style-type: none"> Heads Body: <math>15/32''</math> (L embed) x <math>15/32''</math> Ø Harness: Ø <math>5/8''</math> Control Board <math>3''</math> (w) x <math>2''</math> (d) x <math>1''</math> (h)
Cable length	18' (D) or 32' (L) (specify when ordering)
Material	ABS
Housing color	Transparent
Cable color	<ul style="list-style-type: none"> Emitter Gray (formerly yellow) Receiver Black (formerly green)
Head color	<ul style="list-style-type: none"> Emitter Gray and blue (formerly yellow and black) Receiver Black and blue (formerly green and black)

**SAFETY
PRECAUTIONS**



- Shut off all power going to the header before attempting any wiring procedures.
- Maintain a clean & safe environment when working in public areas.
- Constantly be aware of pedestrian traffic around the door area.
- Always stop pedestrian traffic through the doorway when performing tests that may result in unexpected reactions by the door.
- Always check placement of all wiring before powering up to insure that moving door parts will not catch any wires and cause damage to equipment.
- Ensure compliance with all applicable safety standards (i.e. ANSI A156.10) upon completion of installation.

**MECHANICAL
INSTALLATION**

SINGLE BEAM	DOUBLE BEAM
1. Select a mounting height and mark it on both sides of the door. Make sure it is at least 1' above the floor.	1. Select 2 mounting heights and mark them. Make sure that the beams are at least 1' apart and the lower beam is at least 1' above the floor.
2. Drill a 1/2" (13mm) hole in each side of the door frame.	2. Drill two 1/2" (13mm) holes in each side of the door frame at least 1' apart.
3. Slide the heads and the cables into the vertical jambs.	3. Slide the heads and the cables into the vertical jambs. Make sure you reverse the emitters and receivers for each beam. Emitter A should be on the same side of the door as Receiver B and Emitter B should be on the same side as Receiver A.
4. Fix the control box in the header using double sided foam tape.	4. Fix the control box in the header using double sided foam tape.
5. Connect wires (see next page)	5. Connect wires (see next page)

IMPORTANT NOTE:

When installing a dual beam system, the receivers should never be placed on the same side. Each side should have an emitter and a receiver. See below:

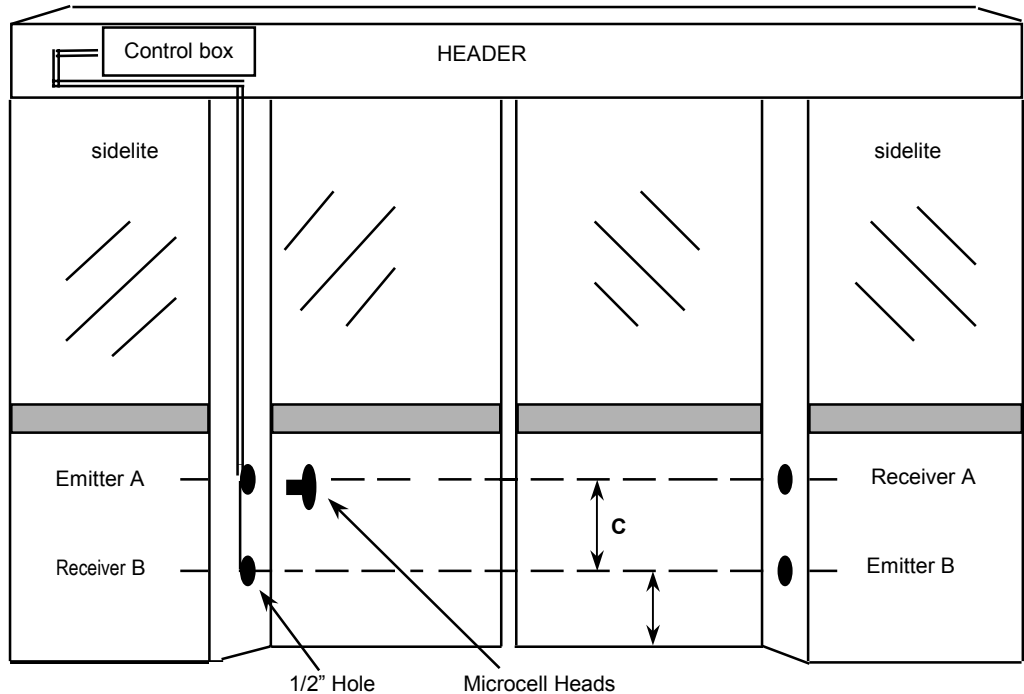

NOTE: Wire routing through breakaway sidelites

NOTE: dimensions C & D should be no less than 1' each

**ELECTRICAL
INSTALLATION**

1. Remove the safety beam control box to access the connectors and the dipswitches.
2. Connect the Microcell cables as shown below.
Black cables = Receivers ("R")
Gray cables = Emitters ("E")

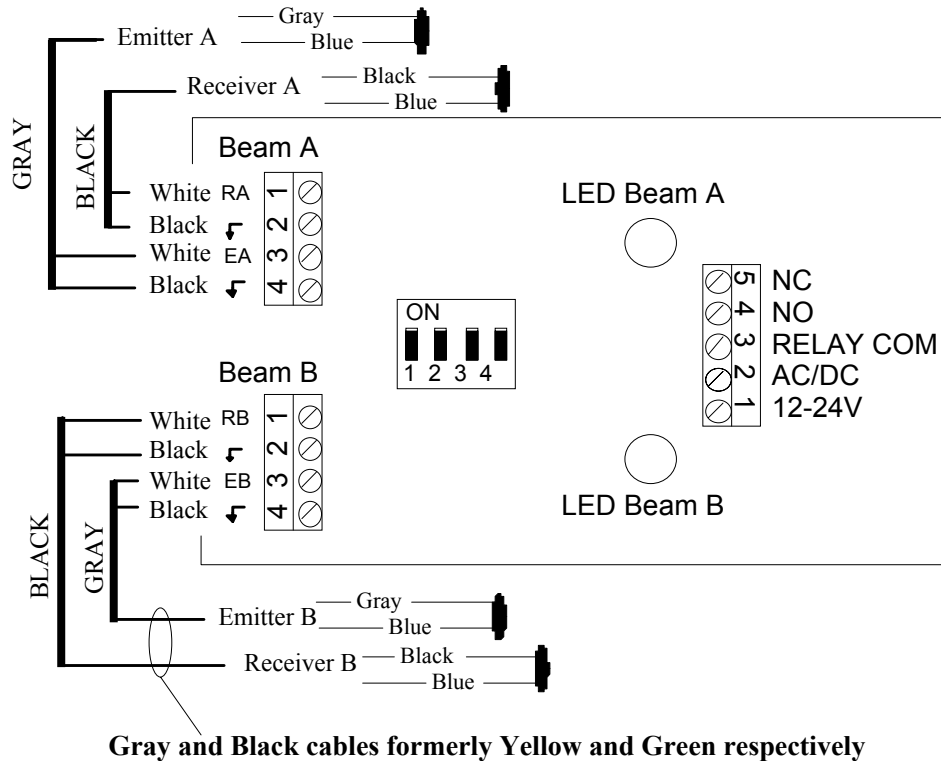

3. Set the operation of the safety beams with the dip switches.

DIP SWITCH	ON	OFF
# 1	Double beams	Single beams
# 2	Normally Open Relay energizes upon detection	Normally Closed Relay de-energizes upon detection
# 3	Standard operating range (15')	Reduced operating range (10')
# 4	Test	Default

NOTE 1:

When using a single set of beams, connect beams to the Beam A connector and set dipswitch #1 to the OFF position

NOTE 2:

If the Microcell is connected to a safety circuit of an automatic door, it is recommended to place dipswitch #2 to the OFF position, and use the normally closed circuit (terminal 3 & 5).

4. Connect 12 - 24 V AC \pm 10% or 12 - 24 V DC -5% / +30% to terminals 1&2 of the control connector.
5. Connect the desired relay output to the door control.
6. Install control box cover.

TROUBLE-SHOOTING

The control box is equipped with two LED's for trouble shooting purposes. Each LED corresponds to one beam.

- When the two LED's are off, the beams are uninterrupted.
- If one or both of the LED's are on, the corresponding beam(s) is interrupted.
- If neither of the LED's will light up, there is a power problem.

During installation with the LEDs visible, it is useful to use them as indicators to assist in aligning the heads.

SYMPTOM	PROBABLE CAUSE	CORRECTIVE ACTION
LED A is continuously on	Improper wiring	<ul style="list-style-type: none"> - Verify the connection of the emitter and the receiver. - Verify that DIP switch No. 1 is in the OFF position if using a single beam.
LED A and/or LED B is continuously on	Improper wiring Poor alignment Incorrect power supply	<ul style="list-style-type: none"> - Verify the connection of the emitter and the receiver. - Verify the positions of the DIP switches. - Verify the power supply with a voltmeter. - Verify the alignment of the emitter and receiver. Max. 8° misalignment - Check distance of beam separation between emitter and receiver. Max. distance is 15' - For dual beam applications, insure that there is at least 1' separation between the upper and lower beam - For dual beam applications, insure that the emitter and receiver sets alternate in pattern. See page 2 - For dual beam applications, insure that the wiring for emitter A corresponds to receiver A, and likewise for set B.
The LED's function, but the door does not respond	Improper wiring of the output relay	<ul style="list-style-type: none"> - Verify the wiring of the output relay. - Verify that DIP switch No. 2 is properly set.

ACCESSORIES

- Jamb Cap Kit: PN: 20.0045: Provides a surface mounted housing for Microcell Head.

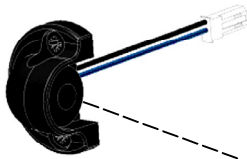

COMPANY CONTACT

If after troubleshooting a problem, a satisfactory solution cannot be achieved, please call B.E.A., Inc. for further assistance during **Eastern Standard Time at 1-800-523-2462 from 8am - 5pm.** For after-hours, call East Coast: 1-866-836-1863 or 1-800-407-4545 / Mid-West: 1-888-308-8843 / West Coast: 1-888-419-2564. **DO NOT leave any problem unresolved.** If you must wait for the following workday to call B.E.A., leave the door inoperable until satisfactory repairs can be made. **NEVER sacrifice the safe operation of the automatic door or gate for an incomplete solution.**
Web: www.beasensors.com